

Toshiba TF7P2 PoCL Industrial Camera



Key features

- 1/3" 3-CCD Microprism System
- XGA format
- Camera Link, Power Over Camera Link
- 90 FPS (partial scan)

Specifications:

- Ultra compact (approx 44x44x78mm) one-piece system
- Output 1024 x 768 pixels
- Progressive Scan
- 8-bit RGB, Digital output (Camera Link)
- Auto and manual white balance
- Auto and manual electronic shutter
- On-screen menu
- Weight 165 g. (without lens)

Description:

The Toshiba IK-TF7P2 is a NEW PoCL (Power over Camera Link) Industrial Camera. It is suitable for capturing fast moving objects in Machine Vision Applications providing accurate colours and high resolution of fast moving objects.

It is a lightweight one piece 1/3" 3-CCD compact camera having 1024 x 768 output pixels with 8-bit RGB, digital signal and sync signals in Camera Link format.

The camera has many suitable applications in Industrial Imaging including process control inspection and machine vision applications such as:

- IC Circuit Inspection
- Automotive Industry
- Flat Panel Inspection
- Food sorting
- Pharmaceuticals

Contact SeeSense for lens options for the Toshiba IK-TF7P2

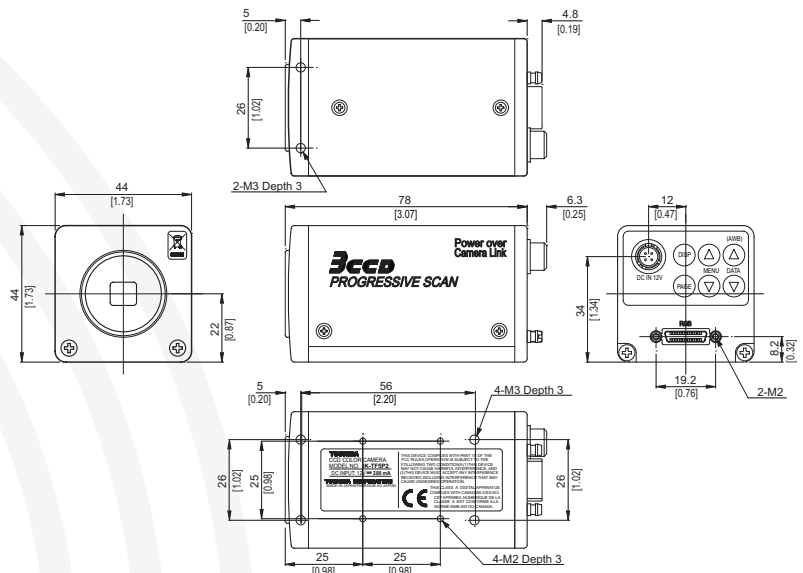
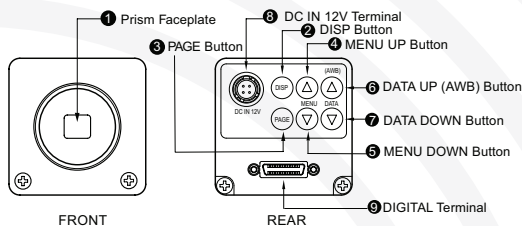

TOSHIBA

Rev: 2.026.1012 E&O.E.

Specification Performance

Power Requirements	12 VDC \pm 10% (PoCL connector or DC input connector)
Power Consumption	3.2 watts (in Normal mode) 3.4 W (in Partial Scanning)
Pick-up System	RGB, 3-CCD
Image Sensor	3-CCD 1/3" Microprism System
Effective Pixels	Horizontal : 1034 Vertical : 779
Output Pixels	Horizontal: 1024, Vertical: 768
Scanning System	Progressive scan
Scan Frequency	Horizontal : 23.229 kHz, Vertical : 29.18 Hz
Sync System	Internal / External (Automatic switching)
Horizontal Resolution	768 TV Lines
Sensitivity	F6.8 Standard (2000 lux, 3000K)
Signal / Noise Ratio	62 dB
Min. Illumination	14 lux standard (F2.2, Sensitivity + 18 dB, 3000K)
Video Signal Output	8-bit RGB, Digital output (Camera Link format)
Pixel Clock Frequency	24.5454 MHz
Sync. Signal Output	FVAL, LVAL, DVAL (Positive polarity) Pixel Clock
External Sync Input	HD : CC3 (LVDS input) Negative polarity VD : CC4 (LVDS input) Negative polarity
External Trigger Input	CC1 (LVDS input) more than 2 μ s pulse width
Partial Scanning Control Input	CC2 (LVDS input)
Interface	Serial Data Interface : Ser TC (RXD), Ser TFG (TXD)
Camera Mount	C-mount 17.526mm (in Air)
Lens flange back maximum	Less than 4mm
Dimensions	44 x 44 x 78mm
Weight	165 grammes
Operating Temperature	0°C to + 40°C
Storage Temperature	-20°C to + 60°C
Humidity	Less than 90% (non-condensing)
Power connector	Hirose HR10A-7P-4S

Specification Features

Shutter	Manual – Off (1/100s, 1/250s, 1/500s, 1/1000s, 1/2000s, 1/4000s, 1/10000s, 1/25000s, 1/50000s, 1/100000s)
Gain	MANUAL (0-18dB; 1dB step), OFF (0 dB)
Partial Scanning	40, 42, 50, 60, 70, 80 & 90 fps
Binning	NONE
White Balance	AWB (Automatic White Balance) Manual (Manually Adjustable)
White Pixel compensation	32 pixels (maximum)
Noise Reduction	ON, OFF (Menu Setting)

Recommended Accessories

Lenses

SeeSense can use its diverse experience to offer a range of lenses, many of which have been tested by SeeSense and are known to be compatible with this camera.

If you have a specific requirement please contact SeeSense for best advice.

Accessories

Power Supply
Toshiba ACM-601E Medical grade power supply

Also available:

IK-TF5P2 1/3" 3-CCD 640 x 480 vGA Camera

Contact SeeSense for best advice

TOSHIBA

Rev: 2.026.1012 E&O.E.